

## Quick, Efficient Communications

The CJ1M extends the CJ1 Series to meet the reduced requirements of more compact machine designs: greater functionality, less memory and built-in I/O. The CJ1M provides a low-cost solution for applications with lower I/O counts and shorter programs compared to the more powerful CJ1G/H CPUs. All CJ1 Series use the same instruction set and I/O modules, so existing programs and equipment can be easily reused in small and large-scale installations. A common memory area and powerful serial link among nine CJ1M CPUs can help integrate processes or coordinate activities.

Two of the four CJ1M CPUs offer integrated I/O with programmable functionality normally found in six separate I/O modules. In CJ1M-CPU22/23 models, 10 inputs and 6 outputs are built in. They can operate as general-purpose DC I/O, 4 interrupt inputs, 4 pulse catch inputs, 2 high-speed counters, and pulse train outputs for 1 or 2-axis positioning.



CLASS I DIV 2

- Same instruction set as the more powerful CJ1G/H
- Completely compatible with all CJ1 I/O
- Smallest CJ1 in physical size; CPU12 and CPU13 are just 1 1/4" wide
- Up to 64 MB flash memory available for many time-saving programming uses
- Serial PLC Link allows simple communication among 9 CJ1 PLCs (1 master, 8 slaves)
- A pulse I/O instruction takes advantage of positioning capabilities in the CPU22 and the CPU23
- Easy terminal block connection for built-in I/O (CPU22 and CPU23)
- CPU22 and CPU23 have built-in pulse catch inputs which will detect pulses that are quicker than the CPU cycle time
- Built-in peripheral and RS-232 ports

## CPU Modules

| Model      | Number of I/O points | Maximum number of Expansion Racks | Maximum number of connectable Modules              | Program capacity | Data memory capacity       | LD instruction processing speed | Built-in ports                   | Mountable options           | Built-in I/O   |
|------------|----------------------|-----------------------------------|--|------------------|----------------------------|---------------------------------|----------------------------------|-----------------------------|--|
| CJ1M-CPU12 | 320                  | None                              | 10 Modules   | 10 Ksteps        | 32 Kwords (DM only, no EM) | 100 ns                          | Peripheral port and RS-232C port | Memory Card (compact flash) | None   |
| CJ1M-CPU13 | 640                  | 1 Rack                            | CPU Rack: 10 Modules<br>Expansion Rack: 10 Modules | 20 Ksteps        |                            |                                 |                                  |                             |  |
| CJ1M-CPU22 | 320                  | None                              | 10 Modules   | 10 Ksteps        |                            |                                 |                                  |                             | 10 inputs and 6 outputs<br>Inputs: 4 interrupt inputs (pulse catch);<br>2 high-speed counter inputs<br>(Phase differential: 50 kHz; Single phase: 100 kHz)<br>Outputs: 2 pulse outputs (2 points for positioning, 100-kHz speed control, and PWM output) |
| CJ1M-CPU23 | 640                  | 1 Rack                            | CPU Rack: 10 Modules<br>Expansion Rack: 10 Modules | 20 Ksteps        |                            |                                 |                                  |                             |  |

# Features and Functions

## Serial PLC Link Function

- Simple PLC Link provides a quick and easy-to-understand data link among up to 9 nodes on a serial network. Each node is allocated 10 words of data, and two methods of sharing the data are user-selectable. An Omron Operator Interface Terminal can be used on this network where it counts as one slave node.

- Capabilities: 10 words per PLC can be allocated to PLC Link in a master/slave arrangement
- Network Size: 1 master and 1 to 8 slaves (total of 9 CJ1 PLCs) can exchange data
- Medium: RS-232, using port built into each CPU
- Hardware: CJ1W-CIF11 RS-232 to RS485/422 converter for multi-drop

### All Node Link Method

All Node Link Method shares the information from all nodes with all the connected nodes.

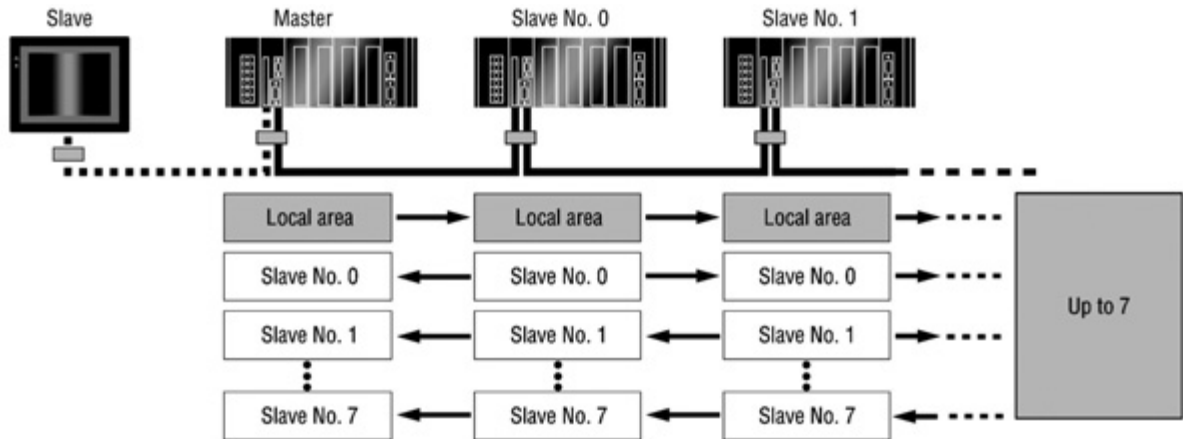

**Note:** An NT/NS-series PT can also be connected as a slave (1:N NT Link). In this case, data can be exchanged via NT Link with the master only. It is allocated one slave node.

### Master Link Method

Master Link Method shares only the master's 10 words with all the other nodes, and the master receives data from all the nodes.

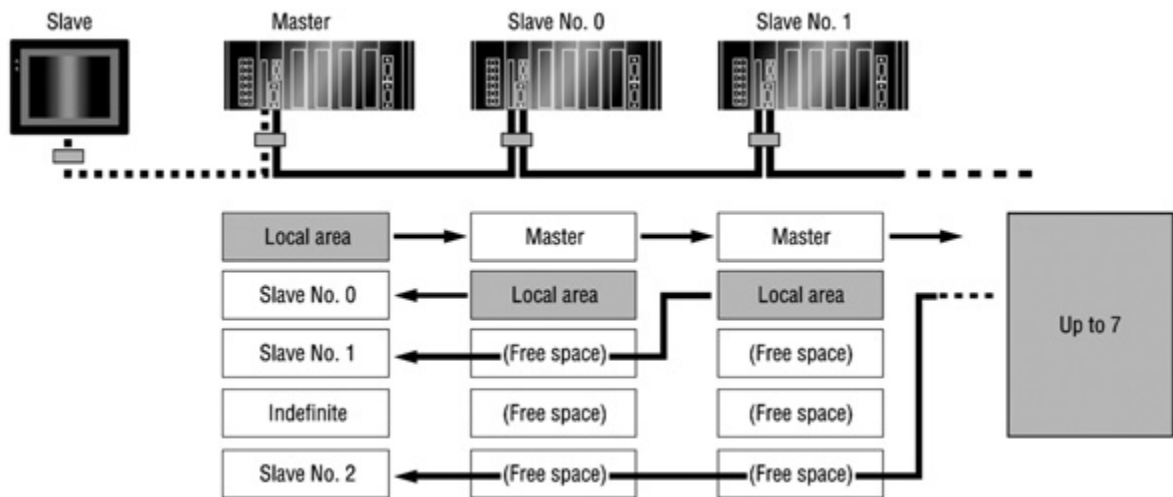

**Note:** An NT/NS-series PT can also be connected as a slave (1:N NT Link). In this case data can be exchanged via NT Link with the master only. It is allocated one slave node.

## Software Requirement

- CX-Programmer Version 3.0 or newer (WS02-CXPXC1-EV□□)

## Integrated I/O in CPU 22 and CPU 23 Only

- 10 inputs and 6 outputs (can be configured as general purpose or special purpose)

- 4 interrupt inputs (pulse catch)
- 2 high-speed counter inputs (phase differential: 50 kHz: Single phase: 100 kHz)
- 2 pulse outputs: (2 points for positioning 100 kHz speed control, or PWM output)

# CJ1M-CPU22/23 Specifications

## ■ Built-in I/O Allocation Areas

### Inputs

| I/O point                          | IN0                                   | IN1   | IN2   | IN3   | IN4   | IN5   | IN6  | IN7  | IN8  | IN9  |
|------------------------------------|---------------------------------------|---|---|---|---|---|--|--|--|--|
| Word                               | 2960                                  |   |   |   |   |   |  |  |  |  |
| Bit                                | 0                                     | 1   | 2   | 3   | 4   | 5   | 6  | 7  | 8  | 9  |
| General-purpose input              | General-purpose input 0               | General-purpose input 1                         | General-purpose input 2                       | General-purpose input 3                         | General-purpose input 4                         | General-purpose input 5                         | General-purpose input 6  | General-purpose input 7  | General-purpose input 8  | General-purpose input 9  |
| Interrupt input                    | Interrupt input 0                     | Interrupt input 1                               | Interrupt input 2                             | Interrupt input 3                               | -   | -   | -  | -  | -  | -  |
| Quick response (pulse catch) input | Quick response (pulse catch) input 0  | Quick response (pulse catch) input 1            | Quick response (pulse catch) input 2          | Quick response (pulse catch) input 3            | -   | -   | -  | -  | -  | -  |
| High-speed counter input           | -                                     | -   | High-speed counter input 1 (phase Z or reset) | High-speed counter input 0 (phase Z or reset)   | -   | -   | High-speed counter input 1 (phase A incremental, or count input) | High-speed counter input 1 (phase B decremental, or direction input) | High-speed counter input 0 (phase A incremental, or count input) | High-speed counter input 0 (phase B decremental, or direction input) |
| Origin search                      | Origin search 0 (origin input signal) | Origin search 0 (origin proximity input signal) | Origin search 1 (origin input signal)         | Origin search 1 (origin proximity input signal) | Origin search 0 (positioning completion signal) | Origin search 1 (positioning completion signal) | -  | -  | -  | -  |

### Outputs

| I/O Input                                    | OUT1                     | OUT2                     | OUT3                       | OUT4                       | OUT5   | OUT6   |
|--|--------------------------|--------------------------|----------------------------|----------------------------|--|--|
| Word   | 2961                     |                          |                            |                            |  |  |
| Bit  | 0                        | 1                        | 2                          | 3                          | 4  | 5  |
| General-purpose output                       | General-purpose output 0 | General-purpose output 1 | General-purpose output 2   | General-purpose output 3   | General-purpose output 4                     | General-purpose output 5                     |
| CW/CCW                                       | Pulse output 0 (CW)      | Pulse output 0 (CCW)     | Pulse output 1 (CW)        | Pulse output 1 (CCW)       | -  | -  |
| Pulse + direction                            | Pulse output 0 (pulse)   | Pulse output 1 (pulse)   | Pulse output 0 (direction) | Pulse output 1 (direction) | -  | -  |
| Pulse with variable duty factor (PWM) output | -                        | -                        | -                          | -                          | PWM output 0                                 | PWM output 1                                 |
| Origin search                                | -                        | -                        | -                          | -                          | Origin search 0 (error counter reset output) | Origin search 1 (error counter reset output) |

## Built-in Input Specifications (CPU22/CPU23 Only)

### ■ Interrupt Inputs and Quick-response Pulse-catch Inputs

| Item  |                      | Specification   |
|---|----------------------|---|
| Number of interrupt and quick response (pulse-catch) input points |                      | 4 total   |
| Interrupt inputs  | Interrupt input mode | At the rising or falling edge of the input signal, the CPUs cyclic program is interrupted and the corresponding I/O interrupt task (task number 140 to 143) is executed. The response time (i.e., the time from the input condition being satisfied until execution of the interrupt task) is 93 $\mu$ s min. |
|   | Counter mode         | The number of rising or falling edges of the input signal are counted incrementally or decrementally, and when the count has been reached, the corresponding interrupt task (task number 140 to 143) is executed. The input response frequency is 1 kHz.  |
| Quick-response (pulse-catch) input                                |                      | Signals less than the cycle time (30 $\mu$ s min.) can be treated as ON signals for one cycle.  |

### ■ High-speed Counter Input

| Item   |                         | Specification   |   |   |  |
|--|-------------------------|---|---|---|--|
| Number of high-speed counter inputs            |                         | 2 (high-speed counters 0 and 1)   |   |   |  |
| Counter modes (set in the PC Setup)            |                         | Phase differential inputs (phase-A, -B, and -Z inputs)  | Up and down pulse inputs (incremental pulse, decremental pulse, and reset inputs) | Pulse + direction inputs (pulse, direction, and reset inputs) | Incremental pulse input (incremental pulse and reset inputs) |
| Response frequency                             | Line driver input       | 50 kHz  | 100 kHz   | 100 kHz   | 100 kHz  |
|  | 24-VDC input            | 30 kHz  | 60 kHz  | 60 kHz  | 60 kHz   |
| Counter type                                   |                         | Linear counter or circular counter (set in the PC Setup)  |   |   |  |
| Counting range                                 |                         | Linear counter: 8000 0000 to 7FFF FFFF Hex<br>Circular counter: 0000 0000 to circular counter set value<br>(The circular counter set value is set in the PC Setup in the range 0000 0001 to FFFF Hex.)  |   |   |  |
| High-speed counter present value storage words |                         | High-speed counter 0: A270 (lower digits) and A271 (upper digits)<br>High-speed counter 1: A272 (lower digits) and A273 (upper digits)<br>Target value comparison inputs and range comparison inputs are possible for these values. The present values are updated each cycle as part of common processing. Use the PRV instruction to read the latest value. |   |   |  |
| Control-method                                 | Target value comparison | Up to 48 target values and interrupt task numbers can be registered.  |   |   |  |
|  | Range comparison        | Up to 8 upper limits, lower limits, and interrupt task numbers can be registered.   |   |   |  |
| Counter reset method                           |                         | Z-phase signal + software reset: Counter reset when the Z-phase input is turned ON with the reset bit (see below) ON.<br>Software reset: Counter reset when the reset bit (see below) turns ON.<br>Reset bit: A531, bit 00 (high-speed counter 0); A531, bit 01 (high-speed counter 1)  |   |   |  |

## Built-in Output Specifications (CPU22/CPU23 Only)

### ■ Positioning and Speed Control Functions

| Item   | Specification  |
|--|--|
| Output frequency                                       | 1 Hz to 100 kHz (1 to 100 Hz: 1-Hz units; 100 Hz to 4 kHz: 10-Hz units; 4 to 100 kHz: 100-Hz units)  |
| Frequency acceleration/<br>deceleration rate           | 1 Hz to 2 kHz (every 4 ms), set in 1-Hz units<br>Acceleration and deceleration for the PLS2 instruction can be set individually.   |
| Changing set values<br>during instruction<br>execution | The target frequency, acceleration/deceleration rate, and target position can be changed. The target frequency and acceleration/deceleration rate can only be changed for positioning at a constant speed.   |
| Pulse output method                                    | CW/CCW or pulse + direction  |
| Number of output pulses                                | Relative coordinate specifications: 0000 0000 to 7FFF FFFF Hex (2,147,483,647 in either incremental or dec-<br>remental direction)<br>Absolute coordinate specifications: 8000 0000 to 7FFF FFFF Hex (-2,147,483,648 to 2,147,483,647)   |
| Instruction for origin<br>search/reset                 | ORG (ORIGIN SEARCH): Used to perform origin searches or origin resets according to set parameters.   |
| Instructions for<br>positioning and speed<br>control   | PLS2 (PULSE OUTPUT): Used to output pulses for trapezoidal positioning with individually set acceleration<br>and deceleration rates.<br>PULS (SET PULSES): Used to set the number of output pulses.<br>SPED (SPEED OUTPUT): Used to output pulses without acceleration or deceleration. (The number of pulses<br>must be set beforehand using the PULS instruction to perform positioning.)<br>ACC (ACCELERATION CONTROL): Used to control the acceleration/deceleration rate.<br>INI (MODE CONTROL): Used to stop pulse output. |
| Pulse output present<br>value storage area             | AR Area Words<br>Pulse output 0: A276 (lower 4 digits) and A277 (upper 4 digits)<br>Pulse output 1: A278 (lower 4 digits) and A279 (upper 4 digits)<br>The present values are updated each cycle as part of overhead processing.<br>The pulse output present value can be read to specified words using PRV (HIGH-SPEED COUNTER PV<br>READ).   |

### ■ Pulse with Variable Duty Factor (PWM) Output Function

| Item                | Specification  |
|---------------------|--|
| Duty ratio          | 0% to 100%, set in 1% units  |
| Frequency           | 0.1 to 999.9 Hz, set in 0.1-Hz units   |
| Instruction for PWM | PWM (PULSE WITH VARIABLE DUTY FACTOR): Used to output pulses with the specified duty factor. |

## Hardware Specifications (CPU22/CPU23 Only)

### ■ Input Specifications

| Item  | Specification  |   |  |                          |
|---|--|---|--|--------------------------|
| Number of input points                        | 10 points  |   |  |                          |
| Input type                                    | 24-VDC input or line driver input (switched with wiring) |   |  |                          |
|   | 24-VDC input   |   | Line driver input  |                          |
|   | Input points   | IN0 to IN5  | IN6 to IN9   | IN0 to IN5    IN6 to IN9 |
| Input voltage                                 | 20.4 to 26.4 VDC   |   | Conforms to RS-422 line driver (equiva-<br>lent to AM26LS31).<br>The power supply voltage on the connect-<br>ed side must be 5 V±5%. |                          |
| Input impedance                               | 3.6 kΩ   | 4.0 kΩ  |  |                          |
| Input current (typ.)                          | 6.2 mA   | 4.1 mA  | 13 mA  | 10 mA                    |
| ON voltage (min.)                             | 17.4 VDC min./3 mA min.                                  |   | -  |                          |
| ON voltage (max.)                             | 5.0 VDC/1 mA max.  |   | -  |                          |
| Response speed (for<br>general-purpose input) | ON response<br>time                                      | 8 ms max. (Select 0, 0.05, 1, 2, 4, 8, 16, or 32 ms in PC Setup.) |  |                          |
|   | OFF response<br>time                                     | 8 ms max. (Select 0, 0.05, 1, 2, 4, 8, 16, or 32 ms in PC Setup.) |  |                          |

■ Circuit Configuration

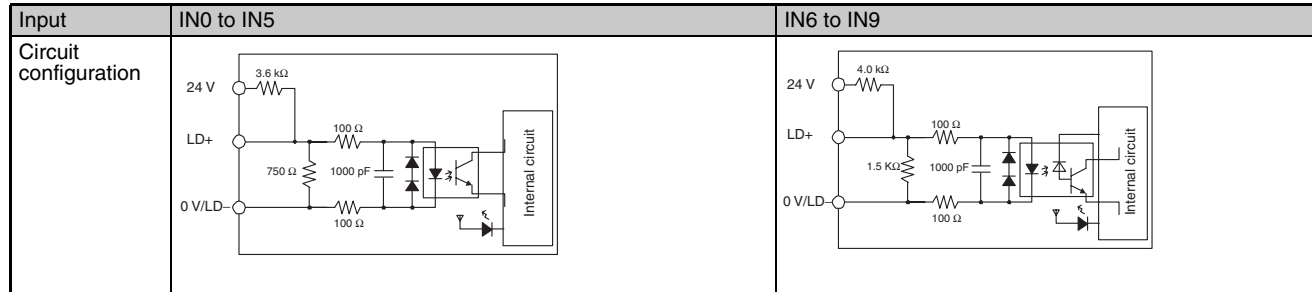

■ General-purpose Output Specifications: Transistor Outputs (Sinking)

| Outputs                   | OUT0 to OUT3                      | OUT4 to OUT5 |
|---------------------------|-----------------------------------|--------------|
| Rated voltage             | 5 to 24 VDC                       |              |
| Allowable voltage range   | 4.75 to 26.4 V                    |              |
| Maximum switching current | 0.3 A per point, 1.8 A per Module |              |
| Outputs per common        | 6 points                          |              |
| Maximum inrush current    | 3.0 A per point for 10 ms max.    |              |
| Leakage current           | 0.1 mA max.                       |              |
| Residual voltage          | 0.6 V max.                        |              |
| ON response time          | 0.1 ms max.                       |              |
| OFF response time         | 0.1 ms max.                       |              |
| Fuse                      | None                              |              |
| External power supply     | 10.2 to 26.4 VDC, 50 mA min.      |              |
| Circuit configuration     |                                   |              |

■ Pulse Output Specifications (OUT0 to OUT3)

| Item                       | Specification           |
|----------------------------|-------------------------|
| Maximum switching capacity | 30 mA, 4.75 to 26.4 VDC |
| Minimum switching capacity | 30 mA, 4.75 to 26.4 VDC |
| Maximum output frequency   | 100 kHz                 |
| Output waveform            |                         |

■ Connector Pin Allocations

| Pin layout | Code   | Name  | Input signal type | Pin No | *1   | Code  | Name  | Input signal type | Pin No | *1  |
|------------|--|---|-------------------|--------|------|---|---|-------------------|--------|-----|
|            | IN0  | General-purpose input 0<br>Interrupt input 0<br>Quick-response (pulse-catch) input 0<br>Origin search 0<br>(Origin Input Signal)  | 24 V DC           | 1      | A1   | IN1   | General-purpose input 0<br>Interrupt input 0<br>Quick-response (pulse-catch) input 0<br>Origin search 0<br>(Origin Proximity Input Signal)  | 24 V DC           | 2      | B1  |
|            |  |   | LD+               | 3      | A2   |   |   | LD+               | 4      | B2  |
|            |  |   | 0 V/LD-           | 5      | A3   |   |   | 0 V/LD-           | 6      | B3  |
|            | IN2  | General-purpose input 2<br>Interrupt input 2<br>Quick-response (pulse-catch) input 2<br>High-speed counter 1<br>(Phase-Z/Reset input)<br>Origin search 1<br>(Origin Input Signal) | 24 V DC           | 7      | A4   | IN3   | General-purpose input 3<br>Interrupt input 3<br>Quick-response (pulse-catch) input 3<br>High-speed counter 0<br>(Phase-Z/Reset input)<br>Origin search 1<br>(Origin Proximity Input Signal) | 24 V DC           | 8      | B4  |
|            |  |   | LD+               | 9      | A5   |   |   | LD+               | 10     | B5  |
|            |  |   | 0 V/LD-           | 11     | A6   |   |   | 0 V/LD-           | 12     | B6  |
|            | IN4  | General-purpose input 4<br>Origin search 0<br>(Positioning Completed Signal)  | 24 V DC           | 13     | A7   | IN5   | General-purpose input 5<br>Origin search 1<br>(Positioning Completed Signal)  | 24 V DC           | 14     | B7  |
|            |  |   | LD+               | 15     | A8   |   |   | LD+               | 16     | B8  |
|            |  |   | 0 V/LD-           | 17     | A9   |   |   | 0 V/LD-           | 18     | B9  |
|            | IN6  | General-purpose input 6<br>High-speed counter 1<br>(Phase-A, Increment, or Count input)   | 24 V DC           | 19     | A10  | IN7   | General-purpose input 7<br>High-speed counter 1<br>(Phase-B, Decrement, or Direction input)   | 24 V DC           | 20     | B10 |
|            |  |   | LD+               | 21     | A11  |   |   | LD+               | 22     | B11 |
|            |  |   | 0 V/LD-           | 23     | A12  |   |   | 0 V/LD-           | 24     | B12 |
| IN8        | General-purpose input 8<br>High-speed counter 0<br>(Phase-A, Increment, or Count input)  | 24 V DC   | 25                | A13    | IN9  | General-purpose input 9<br>High-speed counter 0<br>(Phase-B, Decrement, or Direction input)                                     | 24 V DC   | 26                | B13    |     |
|            |  | LD+   | 27                | A14    |      |   | LD+   | 28                | B14    |     |
|            |  | 0 V/LD-   | 29                | A15    |      |   | 0 V/LD-   | 30                | B15    |     |
| OUT0       | General-purpose output 0 in CW/CCW mode:<br>Pulse output 0 (CW)<br>In Pulse + Direction mode:<br>Pulse output 0 (pulse)        | ---   | 31                | A16    | OUT1 | General-purpose output 1<br>In CW/CCW mode:<br>Pulse output 0 (CCW)<br>In Pulse + Direction mode:<br>Pulse output 1 (pulse)     | ---   | 32                | B16    |     |
| OUT2       | General-purpose output 2<br>In CW/CCW mode:<br>Pulse output 1 (CW)<br>In Pulse + Direction mode:<br>Pulse output 0 (direction) | ---   | 33                | A17    | OUT3 | General-purpose output 3<br>In CW/CCW mode:<br>Pulse output 1 (CCW)<br>In Pulse + Direction mode:<br>Pulse output 1 (direction) | ---   | 34                | B17    |     |
| OUT4       | General-purpose output 4<br>Origin search 0<br>(Error Counter Reset Output)<br>PWM(891) output 0                               | ---   | 35                | A18    | OUT5 | General-purpose output 5<br>Origin search 1<br>(Error Counter Reset Output)<br>PWM(891) output 1                                | ---   | 36                | B18    |     |
| ---        | Power supply input (+V) for the output   | ---   | 37                | A19    | ---  | Not used  | ---   | 38                | B19    |     |
| ---        | Output COM   | ---   | 39                | A20    | ---  | Output COM  | ---   | 40                | B20    |     |



# Specifications

| Item                                    |                         | Specification  |   |
|---|-------------------------|--|---|
| Control method                          |                         | Stored program   |   |
| I/O control method                      |                         | Cyclic scan and immediate processing are both possible.  |   |
| Programming                             |                         | Ladder diagram   |   |
| Instruction length                      |                         | 1 to 7 steps per instruction   |   |
| Ladder instructions                     |                         | Approx. 400 (3-digit function codes)   |   |
| Execution time                          | Basic instructions      | 0.1 $\mu$ s min.   |   |
|   | Special instructions    | 0.3 $\mu$ s min.   |   |
| Overhead time                           |                         | 0.5 ms   |   |
| Module connection method                |                         | No backplane (Modules joined together with connectors.)  |   |
| Mounting method                         |                         | DIN track mounting (screw mounting not possible)   |   |
| Number of tasks                         |                         | 288 (cyclic tasks: 32, interrupt tasks: 256)   |   |
| Interrupt types                         |                         | Scheduled interrupts: Interrupts generated at a specified interval based on the CPU's built-in clock.<br>I/O interrupts: Interrupts from Interrupt Input Modules or from built-in inputs (CJ1M-CPU22/23 only).<br>Power OFF interrupts: Interrupt executed when CPU's power is turned OFF.<br>External interrupts: Interrupts from Special I/O Modules and CPU Bus Modules.  |   |
| Calling subroutines from multiple tasks |                         | Supported using global subroutines.  |   |
| CIO (Core I/O) Area                     | I/O area                | Up to 640 (40 words): CIO 000000 to CIO 003915 (words CIO 0000 to CIO 039)<br>Setting of first rack words can be changed from default (CIO 0000) to CIO 0000 to CIO 0999.<br>I/O bits are allocated to Basic I/O Modules.  | These bits can be used as work bits when not used for the applications described on the left. |
|   | Built-in I/O area       | 10 input bits: CIO 296000 to CIO 296009<br>6 output bits: CIO 296100 to CIO 296105<br>Built-in I/O bits are allocated to the CPUs built-in inputs and outputs (CJ1M-CPU22/23 only).  |   |
|   | Link area               | 3,200 (200 words): CIO 100000 to CIO 119915 (words CIO 1000 to CIO 1199)<br>Link bits are used for data links in Controller Link systems.  |   |
|   | CPU Bus Module area     | 6,400 (400 words): CIO 150000 to CIO 189915 (words CIO 1500 to CIO 1899)   |   |
|   | Special I/O Module area | 15,360 (960 words): CIO 200000 to CIO 295915 (words CIO 2000 to CIO 2959)<br>Special I/O Module bits are allocated to Special I/O Modules (10 words per Module).   |   |
|   | Serial PLC Link area    | 90 (90 words): CIO 310000 to CIO 318900 (words CIO 3100 to CIO 3189)<br>Serial PLC Link words are used for data links in Serial PLC Link systems.  |   |
|   | DeviceNet area          | 9,600 (600 words): CIO 320000 to CIO 379915 (words CIO 3200 to CIO 3799)<br>DeviceNet bits are allocated to Slaves for DeviceNet Module remote I/O communications when the master function is used with fixed allocations.<br>Fixed allocation setting 1 Outputs:CIO 3200 to CIO 3263<br>Inputs:CIO 3300 to CIO 3363<br>Fixed allocation setting 2 Outputs:CIO 3400 to CIO 3463<br>Inputs:CIO 3500 to CIO 3563<br>Fixed allocation setting 3 Outputs:CIO 3600 to CIO 3663<br>Inputs:CIO 3700 to CIO 3763 |   |

| Item                          | Specification   |   |
|-------------------------------|---|---|
| Internal I/O area (work bits) | 4,800 (300 words): CIO 120000 to CIO 149915 (words CIO 1200 to CIO 1499)<br>37,504 (2,344 words): CIO 380000 to CIO 614315 (words CIO 3800 to CIO 6143)<br>These bits in the CIO Area are used as work bits in programming to control program execution. They cannot be used for external I/O.          | These bits can be used as work bits when not used for the applications described on the left.   |
| Work area                     | 8,192 (512 words): W00000 to W51115 (words W000 to W511)<br>These bits are used as work bits in programming to control program execution. They cannot be used for external I/O.<br><b>Note</b> When using work bits in programming, use bits in the Work Area first before using bits from other areas. |   |
| Holding area                  | 8,192 (512 words): H00000 to H51115 (words H000 to H511)<br>Holding bits are used to control program execution, and maintain their ON/OFF status when PLC is turned OFF or the operating mode is changed.   |   |
| Auxiliary area                | Read-only: 7,168 (448 words): A00000 to A44715 (words A000 to A447)<br>Read/write: 8,192 bits (512 words): A44800 to A95915 (words A448 to A959)<br>Auxiliary bits are allocated specific functions.  |   |
| Temporary area                | 16 bits (TR0 to TR15)<br>Temporary bits store ON/OFF execution conditions at program branches.  |   |
| Timer area                    | 4,096: T0000 to T4095 (used for timers only)  |   |
| Counter area                  | 4,096: C0000 to C4095 (used for counters only)  |   |
| DM area                       | 32 Kwords: D00000 to D32767<br>Special I/O Module DM Area: D20000 to D29599 (100 words × 96 Module). Used to set parameters for Special I/O Modules.<br>CPU Bus Module DM Area: D30000 to D31599 (100 words × 16 Module). Used to set parameters for CPU Bus Modules.                                   | Used as a general-purpose data area for reading and writing data in word units (16 bits). Words in the DM Area maintain their status when the PLC is turned OFF or the operating mode is changed. |
| Index registers               | IR0 to IR15<br>Store PLC memory addresses for indirect addressing.  |   |
| Task flag area                | 32 (TK0000 to TK0031)<br>Task Flags are read-only flags that are ON when the corresponding cyclic task is being executed and OFF when the corresponding task is not being executed or is in standby status.   |   |
| Trace memory                  | 4,000 words (trace data: 31 bits, 6 words)  |   |
| File memory                   | Memory Cards: OMRON Memory Cards with 15-MB, 30-MB, or 64-MB capacities can be used. (MS-DOS format).   |   |

## ■ Function Specifications

| Item   | Specification  |   |
|--|--|---|
| Constant cycle time                              | Possible: 1 to 32,000 ms (Module: 1 ms)  |   |
| Cycle time monitoring                            | Possible (Module stops operating if cycle is too long): 10 to 40,000 ms (unit: 10 ms)<br><b>Note</b> When the Parallel Processing Mode is used for the CJ1G/H-CPU□□, and CJ1M-CPU□□ the program execution cycle is monitored. Also, a fatal error will occur in the CPU if the peripheral servicing time exceeds 2 s.  |   |
| I/O refreshing                                   | Cyclic refreshing, immediate refreshing, refreshing by IORF(097).<br>The CPU BUS Module I/O REFRESH (DLNK) instruction can be used to refresh CPU Bus Modules (including allocated CIO and DM Area words) when required in the program.  |   |
| Special refreshing for CPU Bus Modules           | Data links for Controller Link Modules, remote I/O communications for DeviceNet Modules, and other special data for CPU Bus Modules are refreshed at the following times.<br>During I/O refresh period or when CPU BUS Module I/O REFRESH (DLNK) instruction is executed.  |   |
| I/O memory holding when changing operating modes | [Possible (using the IOM Hold Bit in the Auxiliary Area)]  |   |
| Load OFF   | All outputs from Output Modules can be turned OFF when the CPU is in RUN, MONITOR, or PROGRAM mode.  |   |
| Input time constant setting                      | Time constants can be set for inputs from CJ-series Basic I/O Modules. The time constant can be increased to reduce influence of noise and chattering or it can be decreased to detect shorter pulses on inputs.   |   |
| Operating mode setting at power-up               | Possible (By default, the CPU will start in RUN mode if a Programming Console is not connected.)   |   |
| Built-in flash memory                            | User program and parameter areas (e.g., PC Setup) are automatically backed up and restored.  |   |
| Memory Card functions                            | Automatically reading programs (autoboot) from the Memory Card when the power is turned ON.  | Possible  |
|  | Program replacement during PLC operation   | Possible  |
|  | Memory Card storage data   | User program: Program file format<br>PC Setup and other parameters: Data file format<br>I/O memory: Data file format (binary), text format, CSV format<br>CPU Bus Module data: Special format |
|  | Memory Card read/write method  | User program instructions, Programming Devices (including CX-Programmer and Programming Console), Host Link computers, AR Area control bits, easy backup operation                            |
| Filing   | Memory Card data can be handled as files.  |   |
| Debugging  | Force-set/reset, differential monitoring, data tracing (scheduled, each cycle, or when instruction is executed)  |   |
| Online editing                                   | One or more program blocks in user programs can be overwritten when CPU is in PROGRAM or MONITOR mode. This function is not supported for block program areas. With the CX-Programmer, more than one program circuit can be edited at the same time.   |   |
| Program protection                               | Overwrite protection: Set using DIP switch.<br>Copy protection: Password set using CX-Programmer.  |   |
| Error check                                      | User-defined errors (i.e., user can define fatal errors and non-fatal errors)<br>The FPD(269) instruction can be used to check execution time and logic of each programming circuit.<br>Error status can be simulated with the FAL and FALS instructions.  |   |
| Error log  | Up to 20 errors are stored in error log. Information includes error code, error details, and time error occurred. It is possible to set whether or not FAL errors are stored in the error log.   |   |
| Serial communications                            | Built-in peripheral port: Programming Device (e.g., CX-Programmer or Programming Console), Host Links, NT Links<br>Built-in RS-232C port: Programming Device (e.g., CX-Programmer), Host Links, no-protocol communications, NT Links, Serial PLC Links   |   |
|  | Serial Communications Module (sold separately): Protocol macros, Host Links, NT Links  |   |
| Clock  | Provided on all models. Accuracy: $\pm 1.5$ min/mo. at 25°C.<br>The accuracy varies with the temperature.<br>Used to store time when power is turned ON and when errors occur.   |   |
| Power OFF detection time                         | 10 to 25 ms (not fixed)  |   |
| Power OFF detection delay time                   | 0 to 10 ms (user-defined, default: 0 ms)   |   |
| Memory protection                                | Held areas: User program, holding bits, Data Memory, and status of counter Completion Flags and present values.<br>If the IOM Hold Bit in the Auxiliary Area is ON, and the PC Setup is set to maintain the IOM Hold Bit status when power is turned ON, the contents of the CIO Area, Work Area, part of the Auxiliary Area, timer Completion Flags and PVs, Index Registers, and Data Registers will be saved. |   |
| Sending commands to a Host Link computer         | FINS commands can be sent to a computer connected via Host Link System by executing Network Communications Instructions from PLC.  |   |

| Item                              | Specification  |
|-----------------------------------|--|
| Remote programming and monitoring | Host Link communications can be used for remote programming and remote monitoring through a Controller Link System or Ethernet network.  |
| Three-level communications        | Host Link communications can be used for remote programming and remote monitoring from devices on networks up to two levels away (Controller Link Network, Ethernet Network, or other network).                                      |
| Storing comments in CPU Module    | I/O comments can be stored in Memory Cards.  |
| Program check                     | Program checks are performed for items such as no END instruction and instruction errors. CX-Programmer can also be used to check programs.  |
| Control output signals            | RUN output: The internal contacts will turn ON (close) while the CPU is operating. (Possible only with CJ1W-PA205R Power Supply).  |
| Battery life                      | 5 years at 25°C (The battery life depends on the ambient operating temperature; 0.75 year min.)<br>(Battery Set: CJ1W-BAT01)<br>Use a replacement battery for which no more than 2 years have expired since the date of manufacture. |
| Self-diagnostics                  | CPU errors (watchdog timer), I/O bus errors, memory errors, and battery errors   |
| Other functions                   | Storage of the number of times power has been interrupted. (Stored in A514)  |

# Dimensions Unit:mm (inch)

## ■ CPU

### CJ1M-CPU12/13

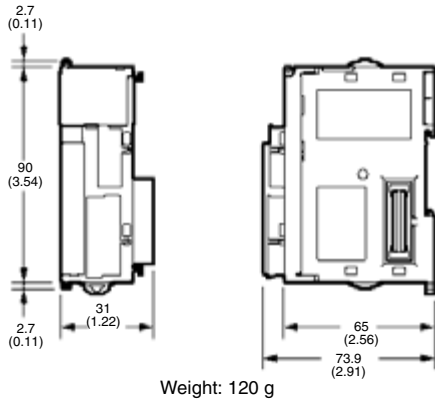

### CJ1M-CPU22/23

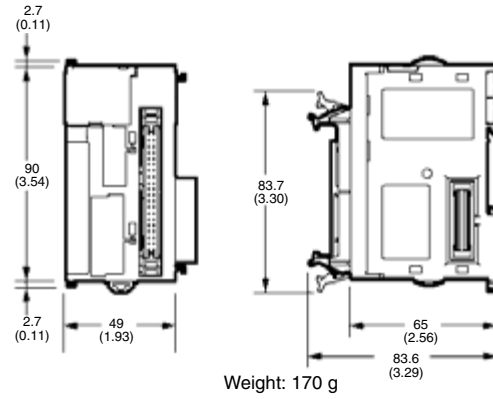

### End Cover (Provided with the CPU)

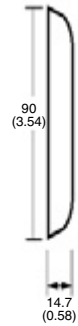

## ■ Power Supply

### Power Supply Units

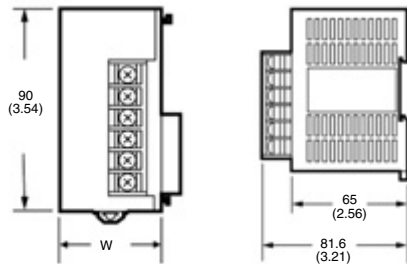

W =

|             |           |
|-------------|-----------|
| CJ1W-PA202  | 45 (1.77) |
| CJ1W-PA205R | 80 (3.15) |
| CJ1W-PD025  | 65 (2.56) |

■ Rack

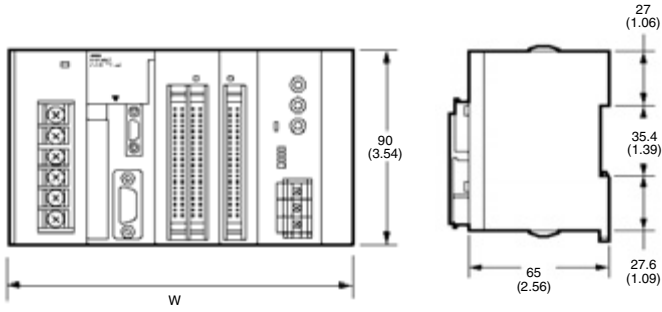

**Note** "W" is determined by total width of power supply, CPU, I/O Modules and end plate.

Width W (mm) When Used With a CJ1W-PA202 Power Supply Module (AC, 14 W)

| Number of I/O Modules with 31 mm width | CJ1M-CPU12/13 | CJ1M-CPU22/23 |
|--|---------------|---------------|
| 1                                      | 121.7 (4.79)  | 139.7 (5.50)  |
| 2                                      | 152.7 (6.01)  | 170.7 (6.72)  |
| 3                                      | 183.7 (7.23)  | 201.7 (7.94)  |
| 4                                      | 214.7 (8.45)  | 232.7 (9.16)  |
| 5                                      | 245.7 (9.67)  | 263.7 (10.35) |
| 6                                      | 276.7 (10.89) | 294.7 (11.60) |
| 7                                      | 307.7 (12.11) | 325.7 (12.82) |
| 8                                      | 338.7 (13.33) | 356.7 (14.04) |
| 9                                      | 369.7 (14.56) | 387.7 (15.26) |
| 10                                     | 400.7 (15.78) | 418.7 (16.48) |

■ Modules

8/16-point Basic I/O Modules

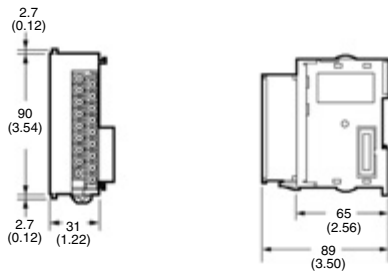

32-point I/O Modules

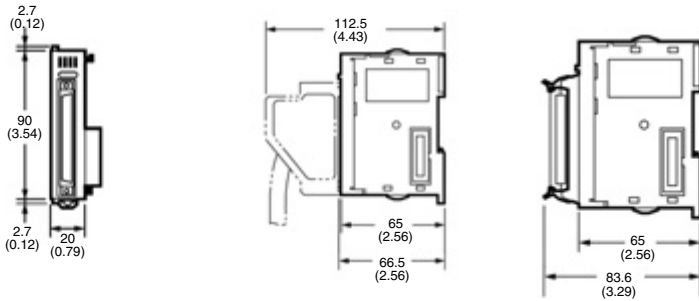

64-point Basic I/O Modules

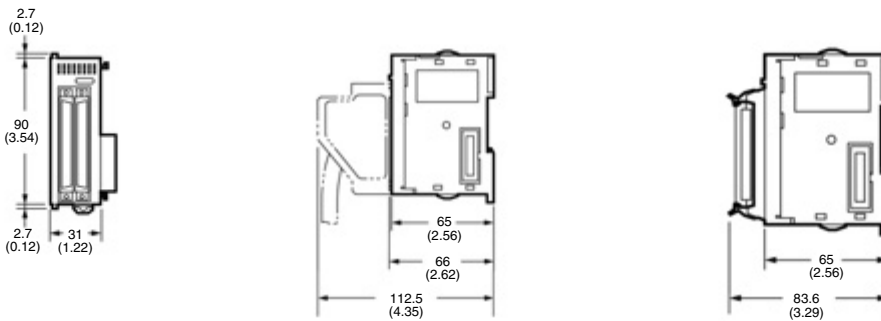

## ■ Accessories

### CJ1W-CIF11

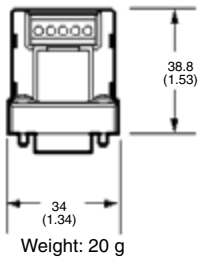

## System Wiring and Cabling

### ■ Standard Connection Method (not for Omron Servo Drives)

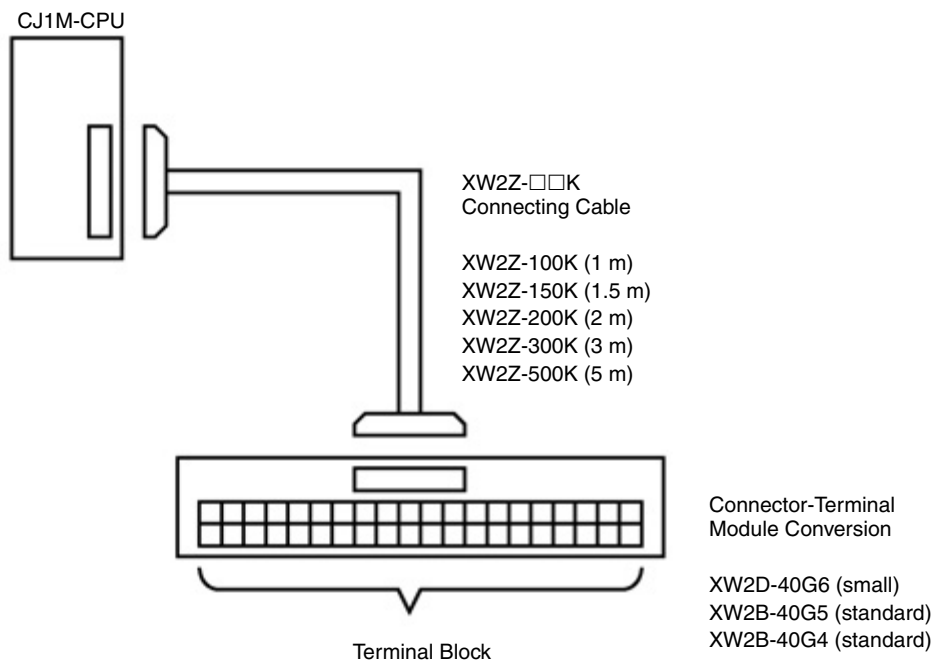

■ Omron SMARTSTEP A-Series Servo Drives (one-axis)

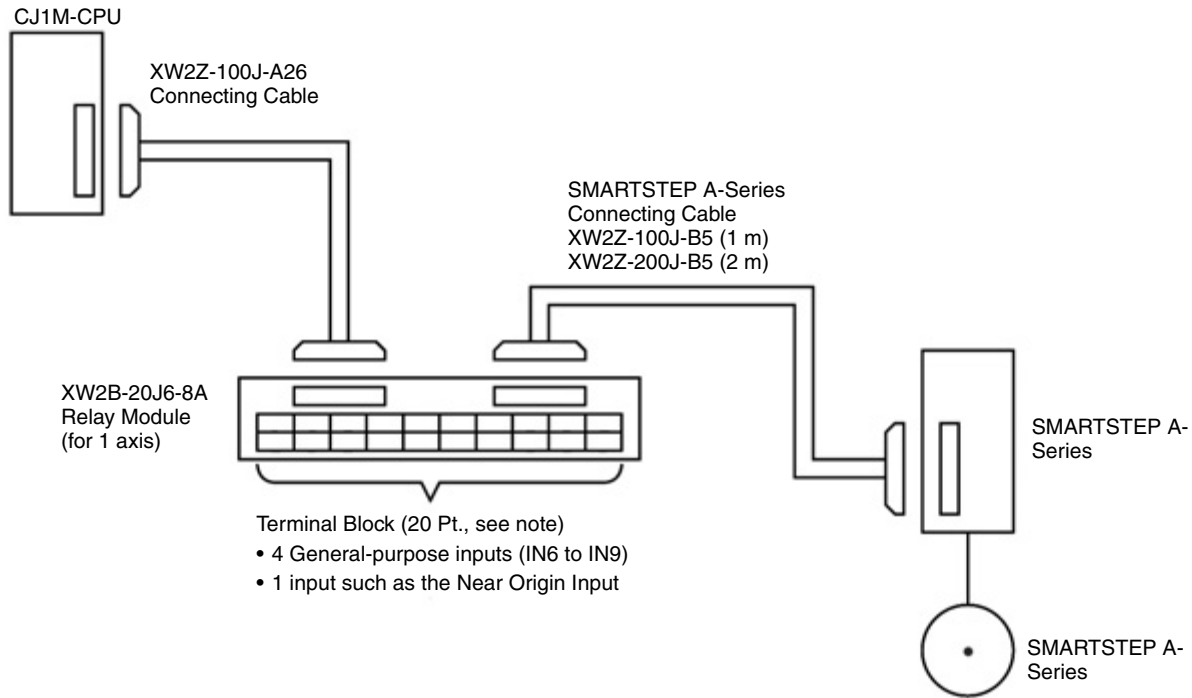

**Note:** When using a One-axis Relay Module (connected to pulse output 0), general-purpose outputs 2 and 3 (OUT2 and OUT3) and PWM (891) output 1 (OUT5) cannot be used.

■ Omron W-Series Servo Drives (one-axis)

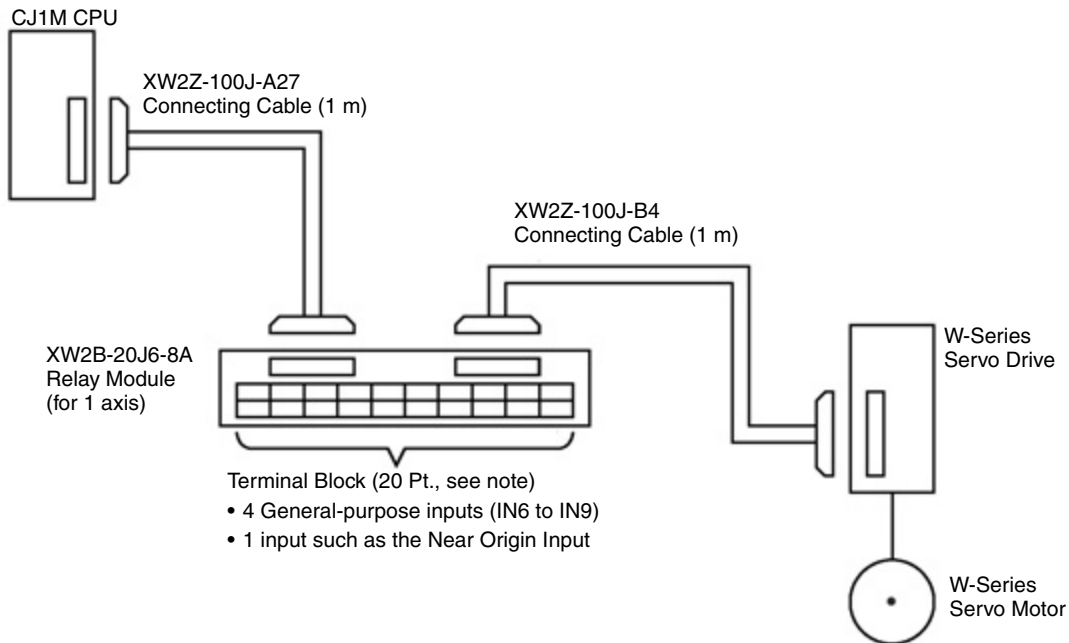

**Note:** When using a One-axis Relay Module (connected to pulse output 0), general-purpose outputs 2 and 3 (OUT2 and OUT3) and PWM (891) output 1 (OUT5) cannot be used.



■ Omron SMARTSTEP A-Series Servo Drives (two-axis)

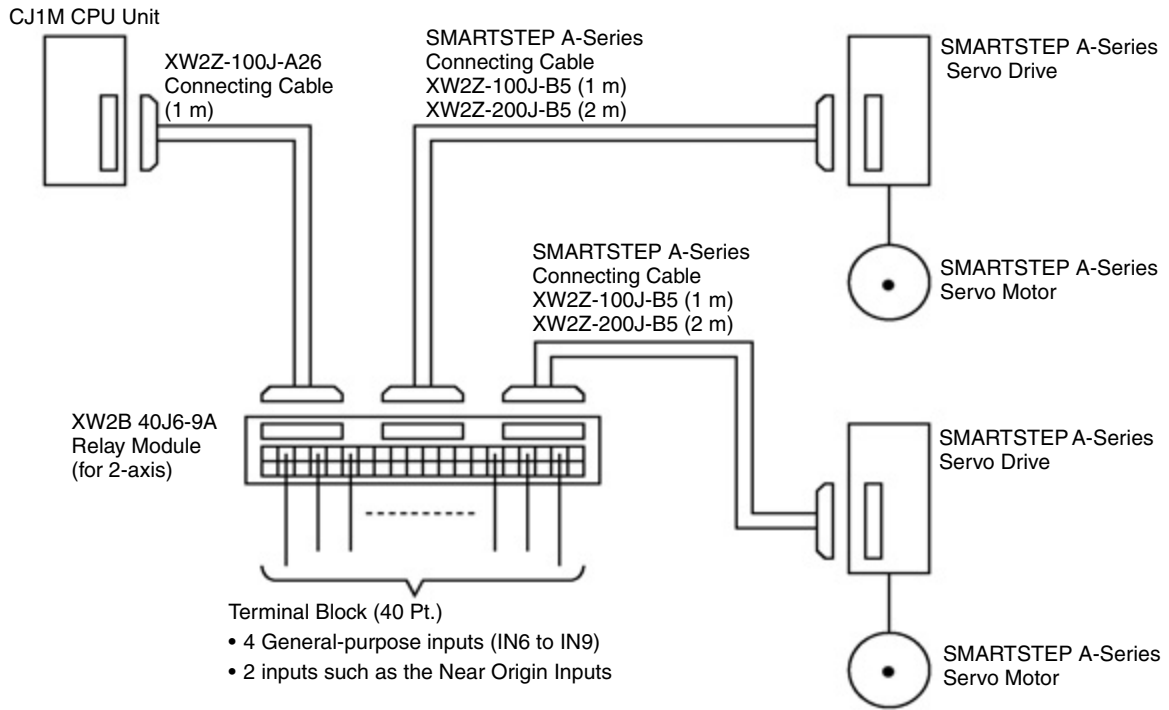

■ Omron OMNUC W-Series, UP-Series, or UT-Series Servo Drives (two-axis)

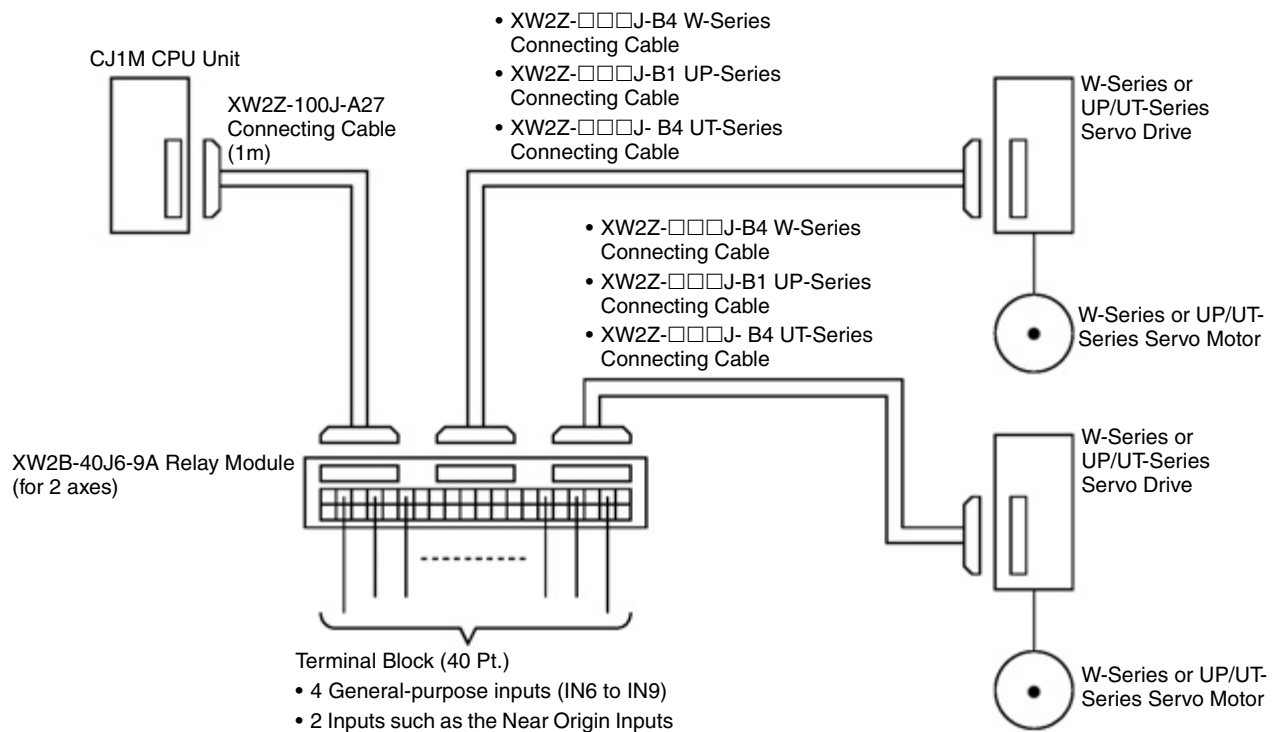

## Ordering Information

| I/O Count | Built-in I/O | Program Capacity | DM Capacity                | LD Instruction Processing Speed | Part Number       |
|-----------|--------------|------------------|----------------------------|---------------------------------|-------------------|
| 320       | No           | 10K steps        | 32K words (DM only, no EM) | 100 nanoseconds                 | <b>CJ1M-CPU12</b> |
| 640       | No           | 20K steps        | 32K words (DM only, no EM) | 100 nanoseconds                 | <b>CJ1W-CPU13</b> |
| 320       | Yes          | 10K steps        | 32K words (DM only, no EM) | 100 nanoseconds                 | <b>CJ1M-CPU22</b> |
| 640       | Yes          | 20K steps        | 32K words (DM only, no EM) | 100 nanoseconds                 | <b>CJ1W-CPU23</b> |

### ■ Accessories for Serial PLC Link

| Description              | Part Number       |
|--------------------------|-------------------|
| RS232 to 422/485 adapter | <b>CJ1W-CIF11</b> |

### ■ Connectors for Built-in I/O Terminal on CPU22/23

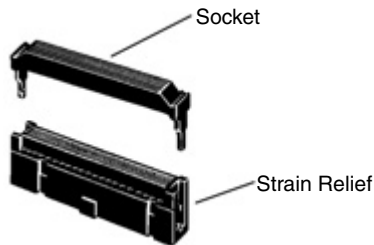

| Item             | Omron Part Number  | 3M Part Number | Daiichi Electronics Part Number |
|------------------|--------------------|----------------|---------------------------------|
| Socket           | <b>XG4M-4030</b>   | 89140-0101     | FRC5-AO40-3TON                  |
| Strain Relief    | <b>XG4M-4004</b>   | 3448-89140     | -----                           |
| Set model number | <b>XG4M-4030-T</b> | -----          | FRC5-AO30-3TOS                  |

### ■ Flash Memory Cards

| Item                | Part Number      | Specifications   |
|---------------------|------------------|--|
| Flash Memory Cards  | <b>HMC-EF172</b> | 15 MB  |
|                     | <b>HMC-EF372</b> | 30 MB  |
|                     | <b>HMC-EF672</b> | 64 MB  |
| Memory Card Adapter | <b>HMC-AP001</b> | Mounts a memory card to fit the PCMCIA card slot on a computer |

### ■ CPU Programming Cables

| Item   | Part Number           | Length | Specifications  |
|--|-----------------------|--------|---|
| Programming Device Connecting Cables (for Peripheral port) | <b>CS1W-CN118</b>     | 0.1 m  | Connects DOS computer, D-Sub, 9-pin receptacle (Converts between RS-232C cable and peripheral port) |
|  | <b>CS1W-CN226</b>     | 2 m    | Connects DOS computer, D-Sub, 9-pin   |
|  | <b>CS1W-CN626</b>     | 6 m    | Connects DOS computer, D-Sub, 9-pin   |
| Programming Device Connecting Cables (for RS-232C port)    | <b>C200H-CN229-EU</b> | 2 m    | Connects DOS computer, D-Sub, 9-pin   |

ALL DIMENSIONS SHOWN ARE IN MILLIMETERS. To convert millimeters into inches, divide by 25.4

**OMRON.****OMRON ELECTRONICS LLC**

One East Commerce Drive  
Schaumburg, IL 60173

**847-843-7900**

For US technical support or other inquiries:

**800-556-6766****OMRON CANADA, INC.**

885 Milner Avenue  
Toronto, Ontario M1B 5V8

**416-286-6465****OMRON ON-LINE**

Global - <http://www.omron.com>

USA - <http://www.omron.com/oei>

Canada - <http://www.omron.com/oci>